

Features

- 225W Peak Pulse Power Dissipation (10ms x 1000ms waveform)
- 5.0V - 51V Standoff Voltages
- Excellent Clamping Capability
- **Lead Free Finish, RoHS Compliant (Note 6)**
- **"Green" Molding Compound (No Br, Sb)**
- **Qualified to AEC-Q101 Standards for High Reliability**

Mechanical Data

- Case: PowerDI®123
- Case Material: Molded Plastic, "Green" Molding Compound. UL Flammability Classification Rating 94V-0
- Moisture Sensitivity: Level 1 per J-STD-020D
- Terminal Connections: Cathode Band
- Terminals: Finish — Matte Tin annealed over Copper leadframe. Solderable per MIL-STD-202, Method 208 
- Marking Information: See Page 3
- Ordering Information: See Page 3
- Weight: 0.01 grams (approximate)



Top View

Maximum Ratings @ $T_A = 25^\circ\text{C}$ unless otherwise specified

| Characteristic | Symbol | Value | Unit |
|--|-----------|-------------|------|
| Peak Pulse Power Dissipation (Note 1) 10/1000 μs (Note 2) 8/20 μs | P_{PK} | 225 1125 | W |
| Peak Forward Surge Current, 8.3ms Single Half Sine Wave | I_{FSM} | 50 | A |
| Instantaneous Forward Voltage @ $I_{FP} = 12\text{A}$ (Note 5) | V_F | 3.5 | V |

Thermal Characteristics

| Characteristic | Symbol | Value | Unit |
|--|-----------------|-------------|--------------------|
| DC Steady-State Power Dissipation (Note 3) | P_D | 1.0 | W |
| Thermal Resistance, Junction to Ambient (Note 3) | $R_{\theta JA}$ | 125 | $^\circ\text{C/W}$ |
| Thermal Resistance, Junction to Soldering Point (Note 4) | $R_{\theta JS}$ | 6 | $^\circ\text{C/W}$ |
| Operating and Storage Temperature Range | T_J, T_{STG} | -65 to +150 | $^\circ\text{C}$ |

- Notes:
1. Non-Repetitive current pulse as shown in figure 2 and derated above $T_A = 25^\circ\text{C}$ as per figure 1.
 2. Non-Repetitive current pulse as shown in figure 3 and derated above $T_A = 25^\circ\text{C}$ as per figure 1.
 3. Device mounted on 1"x1", FR-4 PCB; 2 oz. Cu pad layout as shown on Diodes Inc. suggested pad layout document AP02001.pdf.
 4. Theoretical $R_{\theta JS}$ calculated from the top center of the die straight down to the PCB/cathode tab solder junction.
 5. 1/2 sine wave (or equivalent square wave), pulse width = 8.3ms, duty cycle = 4 pulses/minute maximum.
 6. EU Directive 2002/95/EC (RoHS). All Applicable RoHS Exemptions Applied, see *EU Directive 2002/95/EC Annex Notes*.

PowerDI is a registered trademark of Diodes Incorporated.

Electrical Characteristics @ $T_A = 25^\circ\text{C}$ unless otherwise specified

| Part Number | Reverse Standoff Voltage | Breakdown Voltage V_{BR} @ I_T (Note 7) | | Test Current | Max. Reverse Leakage @ V_{RWM} | Max. Clamping Voltage @ I_{pp} | Max. Peak Pulse Current I_{pp} | Marking Code |
|-------------|--------------------------|---|---------|--------------|----------------------------------|----------------------------------|----------------------------------|--------------|
| | V_{RWM} (V) | Min (V) | Max (V) | I_T (mA) | I_R (μA) | V_C (V) | (A) | |
| DFLT5V0A | 5.0 | 6.40 | 7.0 | 10 | 400 | 9.2 | 24.5 | FAE |
| DFLT6V0A | 6.0 | 6.67 | 7.37 | 10 | 400 | 10.3 | 21.8 | FAG |
| DFLT6V5A | 6.5 | 7.22 | 7.98 | 10 | 250 | 11.2 | 20.1 | FAK |
| DFLT7V0A | 7.0 | 7.78 | 8.60 | 10 | 100 | 12.0 | 18.8 | FAM |
| DFLT7V5A | 7.5 | 8.33 | 9.21 | 1.0 | 50 | 12.9 | 17.4 | FAP |
| DFLT8V0A | 8.0 | 8.89 | 9.83 | 1.0 | 25 | 13.6 | 16.5 | FAR |
| DFLT8V5A | 8.5 | 9.44 | 10.4 | 1.0 | 10 | 14.4 | 15.6 | FAT |
| DFLT9V0A | 9.0 | 10.0 | 11.1 | 1.0 | 5.0 | 15.4 | 14.6 | FAV |
| DFLT10A | 10 | 11.1 | 12.3 | 1.0 | 2.5 | 17.0 | 13.2 | FAZ |
| DFLT11A | 11 | 12.2 | 13.5 | 1.0 | 2.5 | 18.2 | 12.4 | FAZ |
| DFLT12A | 12 | 13.3 | 14.7 | 1.0 | 2.5 | 19.9 | 11.3 | FBE |
| DFLT13A | 13 | 14.4 | 15.9 | 1.0 | 1.0 | 21.5 | 10.5 | FBG |
| DFLT14A | 14 | 15.6 | 17.2 | 1.0 | 1.0 | 23.2 | 9.7 | FBK |
| DFLT15A | 15 | 16.7 | 18.5 | 1.0 | 1.0 | 24.4 | 9.22 | FBM |
| DFLT16A | 16 | 17.8 | 19.7 | 1.0 | 1.0 | 26.0 | 8.65 | FBP |
| DFLT17A | 17 | 18.9 | 20.9 | 1.0 | 1.0 | 27.6 | 8.15 | FBR |
| DFLT18A | 18 | 20.0 | 22.1 | 1.0 | 1.0 | 29.2 | 7.71 | FBT |
| DFLT20A | 20 | 22.2 | 24.5 | 1.0 | 1.0 | 32.4 | 6.94 | FBV |
| DFLT22A | 22 | 24.4 | 26.9 | 1.0 | 1.0 | 35.5 | 6.34 | FBX |
| DFLT24A | 24 | 26.7 | 29.5 | 1.0 | 1.0 | 38.9 | 5.78 | FBZ |
| DFLT26A | 26 | 28.9 | 31.9 | 1.0 | 1.0 | 42.1 | 5.35 | FCE |
| DFLT27A | 27 | 30 | 33.15 | 1.0 | 1.0 | 43.7 | 5.15 | FCF |
| DFLT28A | 28 | 31.1 | 34.4 | 1.0 | 1.0 | 45.4 | 4.96 | FCG |
| DFLT30A | 30 | 33.3 | 36.8 | 1.0 | 1.0 | 48.4 | 4.65 | FCK |
| DFLT33A | 33 | 36.7 | 40.6 | 1.0 | 1.0 | 53.3 | 4.22 | FCM |
| DFLT36A | 36 | 40.0 | 44.2 | 1.0 | 1.0 | 58.1 | 3.87 | FCP |
| DFLT40A | 40 | 44.4 | 49.1 | 1.0 | 1.0 | 64.5 | 3.49 | FCR |
| DFLT43A | 43 | 47.8 | 52.8 | 1.0 | 1.0 | 69.4 | 3.24 | FCT |
| DFLT45A | 45 | 50.0 | 55.3 | 1.0 | 1.0 | 72.7 | 3.10 | FCV |
| DFLT48A | 48 | 53.3 | 58.9 | 1.0 | 1.0 | 77.4 | 2.91 | FCX |
| DFLT51A | 51 | 56.7 | 62.7 | 1.0 | 1.0 | 82.4 | 2.73 | FCZ |

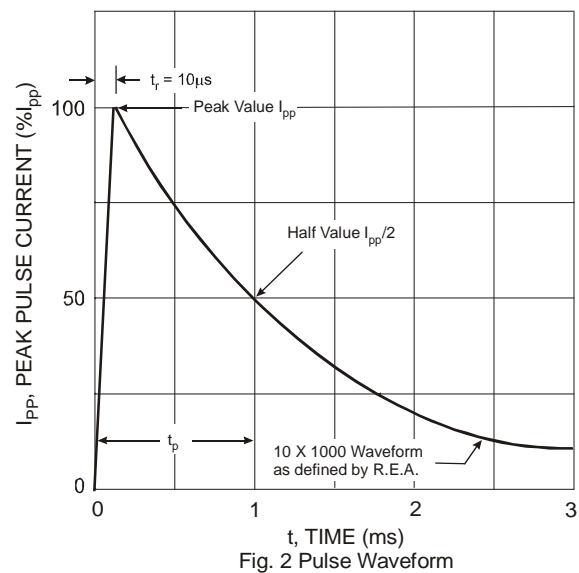
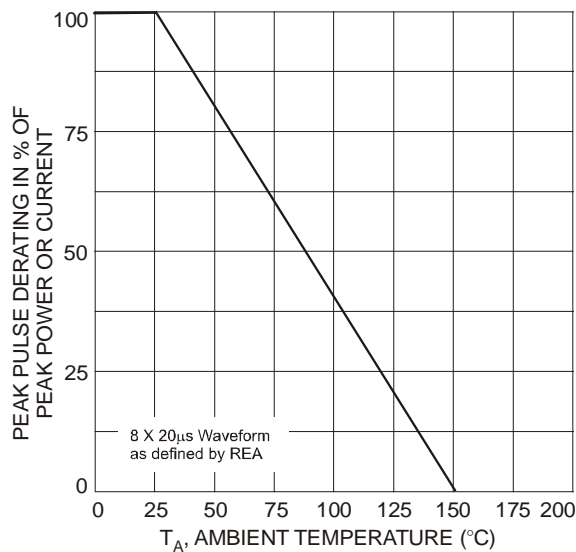
 Notes: 7. V_{BR} measured at pulse test current I_T with $t_p \leq 5.0\text{ms}$ at $T_A = 25^\circ\text{C}$.

PowerDI is a registered trademark of Diodes Incorporated.

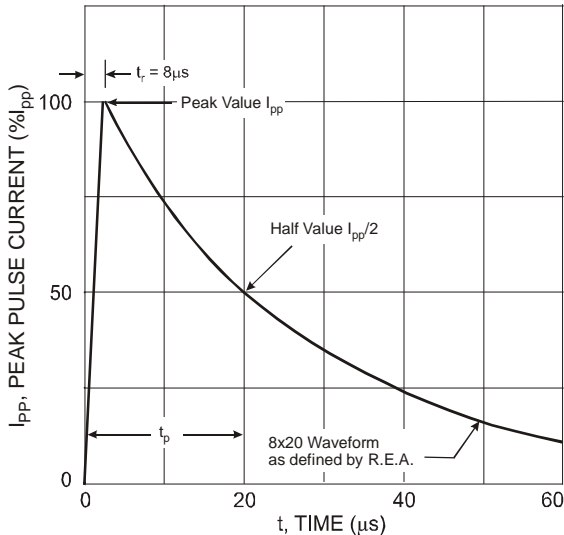

Fig. 3 Pulse Waveform

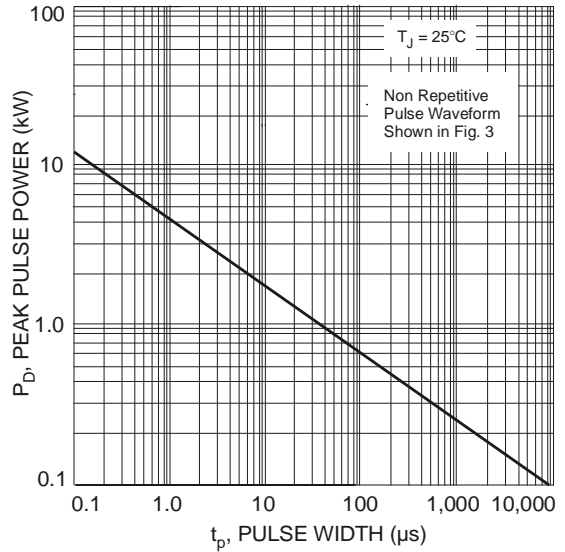

Fig. 4 Pulse Rating Curve

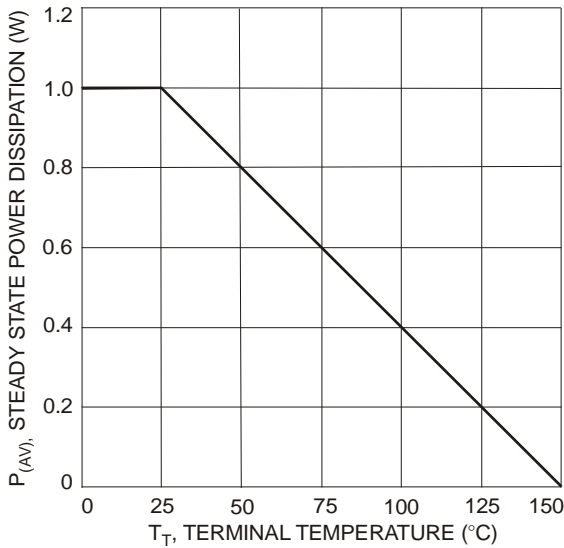

Fig. 5 Steady State Power Derating Curve

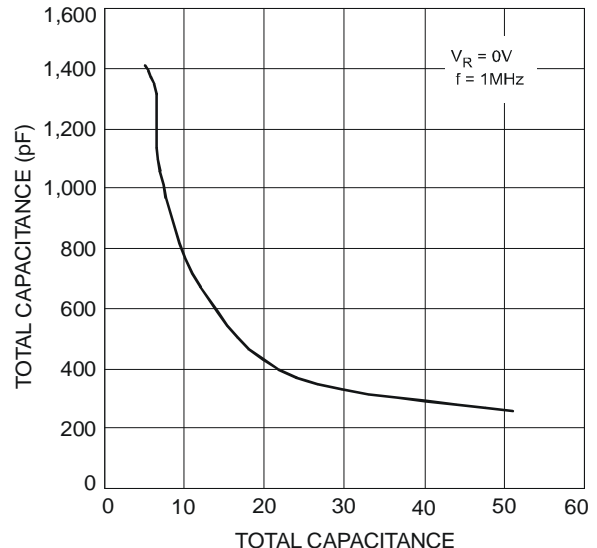

Fig. 6 V_{RWM} (V)

Ordering Information (Note 8)

| Part Number | Case | Packaging |
|-------------|--------------------------|------------------|
| DFLTxxxA-7* | PowerDI [®] 123 | 3000/Tape & Reel |

* Add "-7" to the appropriate type number in Electrical Characteristics Table on page 2. Example: 10V reverse standoff device = DFLT10A-7.

Notes: 8. For packaging details, go to our website at <http://www.diodes.com/datasheets/ap02007.pdf>.

Marking Information

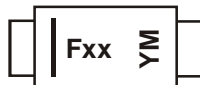

Fxx = Product Type Marking Code,
See Electrical Characteristics Table on Page 2
YM = Date Code Marking
Y = Year (ex: R = 2004)
M = Month (ex: 9 = September)

Date Code Key

| Year | 2004 | 2005 | 2006 | 2007 | 2008 | 2009 | 2010 | 2011 | 2012 | 2013 | 2014 | 2015 |
|-------|------|------|------|------|------|------|------|------|------|------|------|------|
| Code | R | S | T | U | V | W | X | Y | Z | A | B | C |
| Month | Jan | Feb | Mar | Apr | May | Jun | Jul | Aug | Sep | Oct | Nov | Dec |
| Code | 1 | 2 | 3 | 4 | 5 | 6 | 7 | 8 | 9 | O | N | D |

PowerDI is a registered trademark of Diodes Incorporated.

Package Outline Dimensions

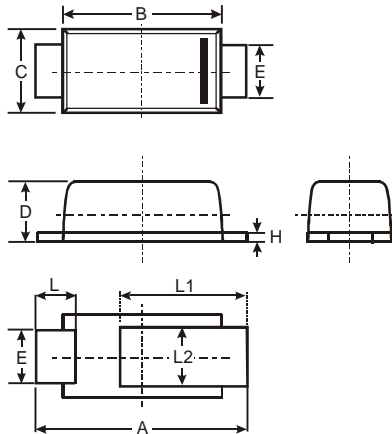

| PowerDI [®] 123 | | | |
|--------------------------|------|------|------|
| Dim | Min | Max | Typ |
| A | 3.50 | 3.90 | 3.70 |
| B | 2.60 | 3.00 | 2.80 |
| C | 1.63 | 1.93 | 1.78 |
| D | 0.93 | 1.00 | 0.98 |
| E | 0.85 | 1.25 | 1.00 |
| H | 0.15 | 0.25 | 0.20 |
| L | 0.55 | 0.75 | 0.65 |
| L1 | 1.80 | 2.20 | 2.00 |
| L2 | 0.95 | 1.25 | 1.10 |
| All Dimensions in mm | | | |

Suggested Pad Layout

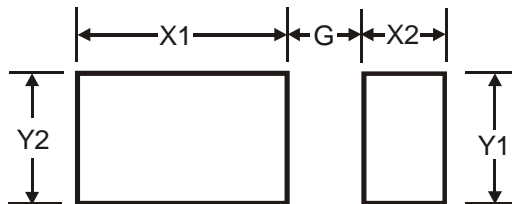

| Dimensions | Value (in mm) |
|------------|---------------|
| G | 1.0 |
| X1 | 2.2 |
| X2 | 0.9 |
| Y1 | 1.4 |
| Y2 | 1.4 |

IMPORTANT NOTICE

Diodes Incorporated and its subsidiaries reserve the right to make modifications, enhancements, improvements, corrections or other changes without further notice to any product herein. Diodes Incorporated does not assume any liability arising out of the application or use of any product described herein; neither does it convey any license under its patent rights, nor the rights of others. The user of products in such applications shall assume all risks of such use and will agree to hold Diodes Incorporated and all the companies whose products are represented on our website, harmless against all damages.

LIFE SUPPORT

Diodes Incorporated products are not authorized for use as critical components in life support devices or systems without the expressed written approval of the President of Diodes Incorporated.